

The AN100 Announcer™

AN100Q#

**Made in
USA**

The Announcer™ is a small and efficient device for playing pre-recorded voice and audio messages. It is exactly the same size as a piezo alarm. The Announcer can act as a direct replacement wherever standard piezo alarms are used.



The Announcer will play a single message stored in memory up to 10 seconds in length. Upon the application of power the message will continue to repeat until power is removed. Custom versions are available which play the message a single time.

Some uses include:

- Playing promotional messages during an in-store or trade show promotional display.
- Adding safety and awareness to vehicles or machines by replacing an ambiguous “beep.”
- Broadcasting a message in public places such as shopping malls, museum information plaques, airports, building lobbies, casinos/gaming machines, restaurants, movie theatres, kiosks, gas station pumps, etc.
- The applications for a self-contained playback device are limitless. Just add power!

SPECIFICATIONS

Operating Mode:	Play message or tone when power is applied. Standard messages are: AN100Q1: “Warning” AN100Q2: “Caution” AN100Q3: “Equipment Malfunction” AN100Q4: “Vehicle in Motion” <i>*Custom Messages also available. Contact manufacturer for more information.</i>
Operating Voltage:	9-15 VDC
Nominal Operating Voltage:	12 VDC
Frequency Response:	750 Hz to 4KHz
Typical Operating Current:	250mA peak @ 12Vdc <i>*input current is proportional to content of message</i>
Typical Sound Pressure:	85±5 dB(A), at 24 inches (61 cm), at 25°C <i>*Average output based on content of message.</i>
Termination:	2 .25" Quick Connect Blades
Termination Strength:	Pull test with a maximum of 22 pounds (10 kg) load
Operating Temperature:	0°C to +60°C.
Storage Temperature:	-40°C to +60°C.
Surge Voltage:	20% over maximum rated voltage for less than 5 minutes.
Reverse Voltage Protection:	To the maximum operating voltage.
Construction Materials:	Case- Plastic “NORYL® N-190”, Flame Retardant UL 94-VO, Black

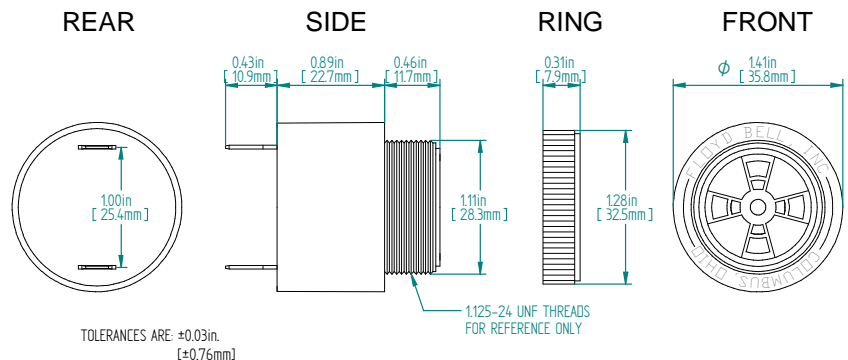
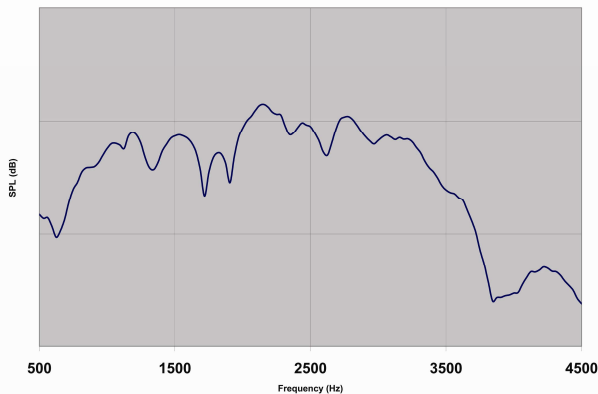

 **Floyd Bell Inc**
An ISO 9001:2000 Registered Company

720 Dearborn Park Lane • Columbus, OH 43085
Tel: 614/294-4000 • Fax: 614/291-0823
Website: www.floydbell.com

Revision: 12.08